

ohne Flansch  
without Flange

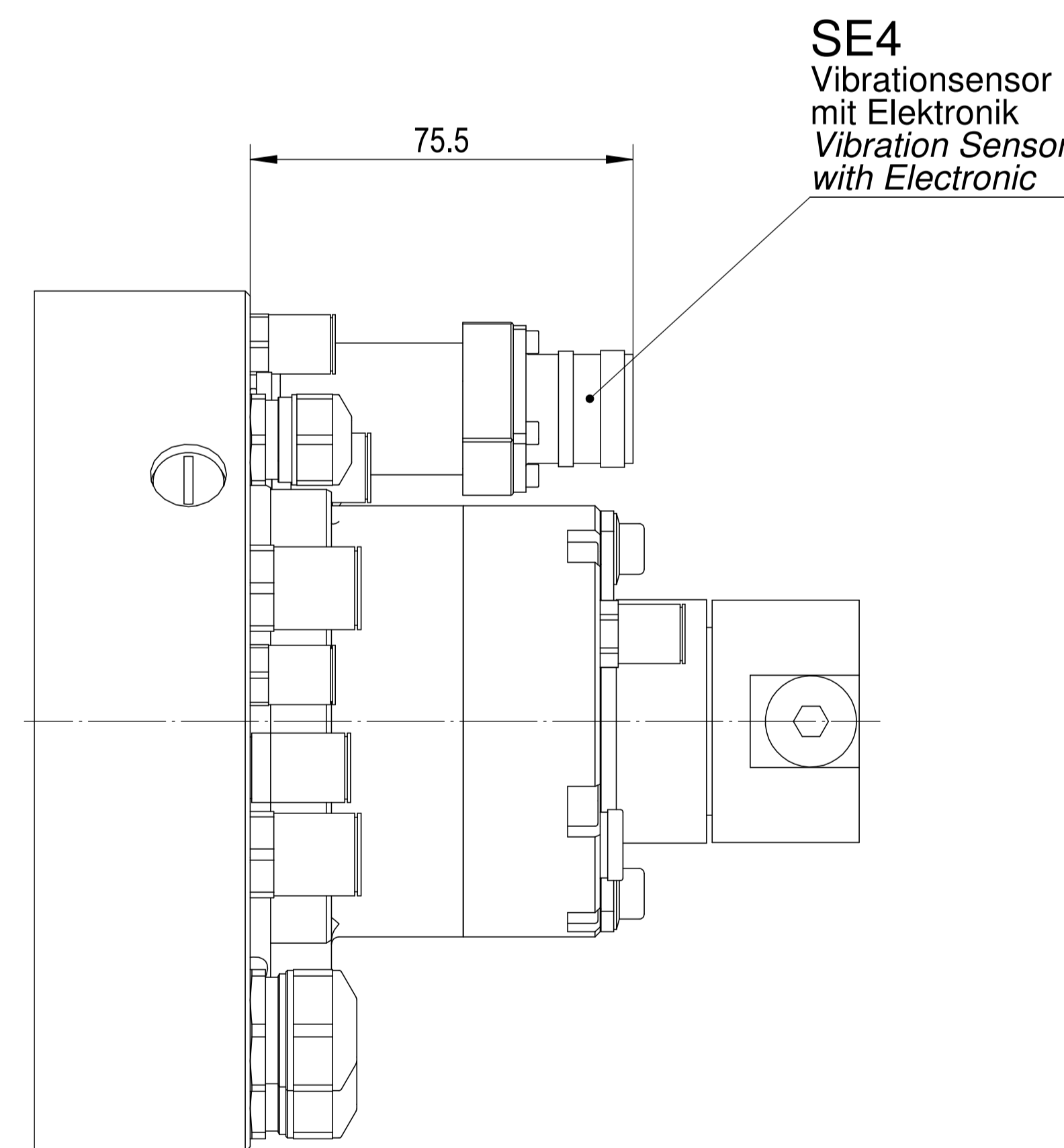
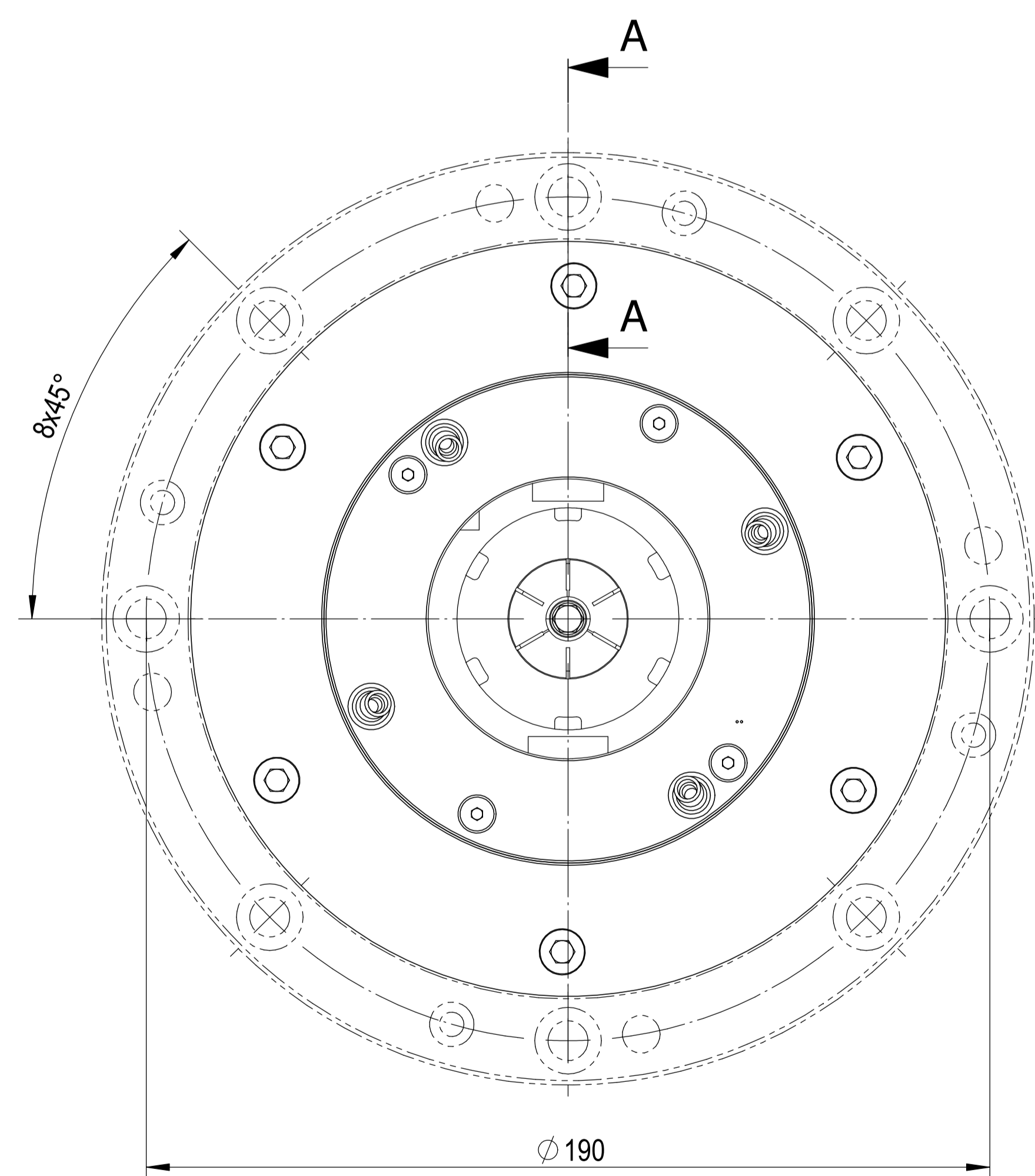
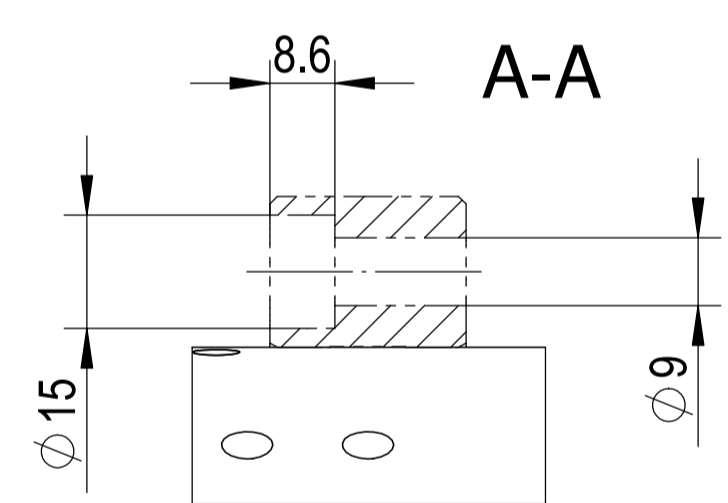
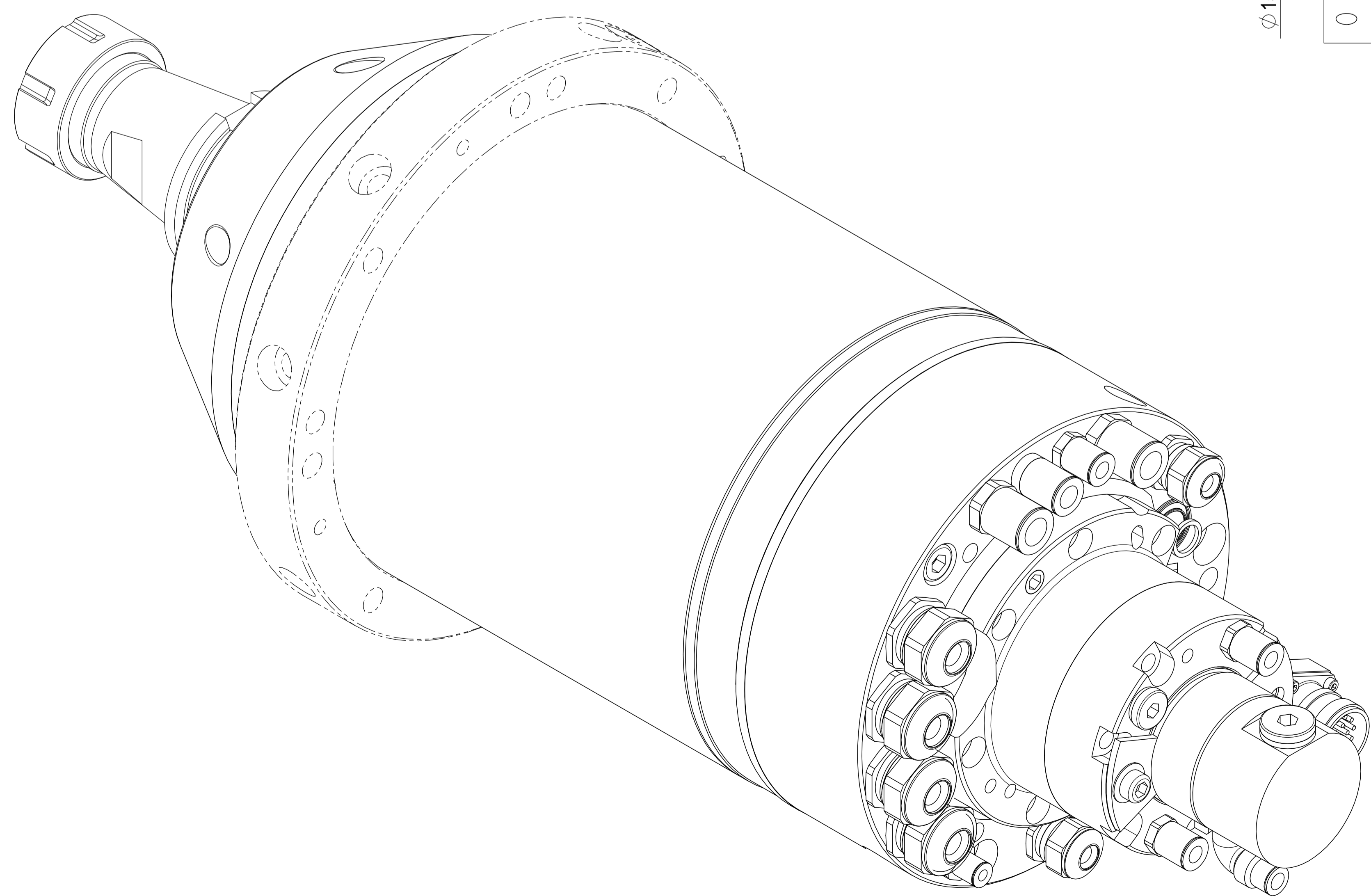
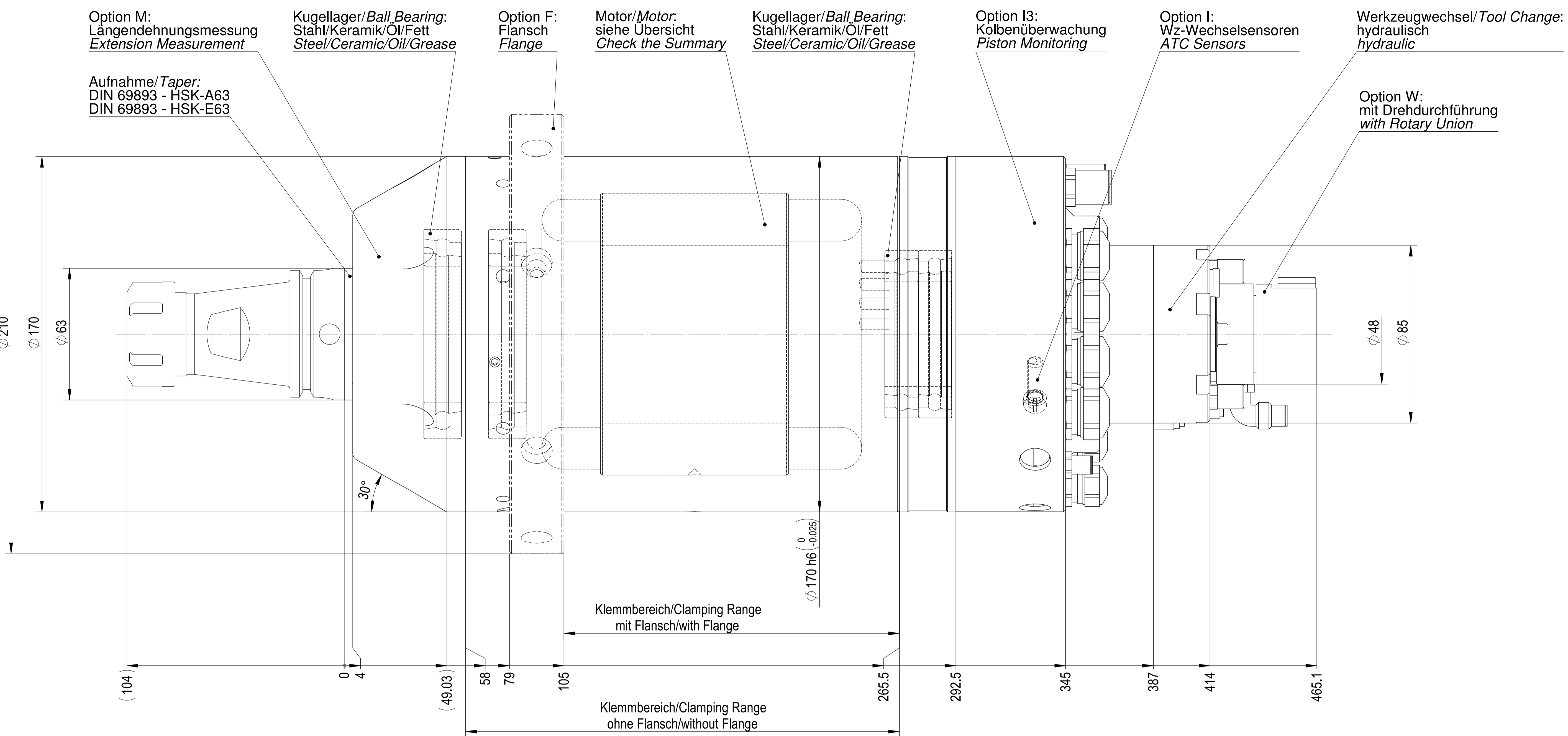
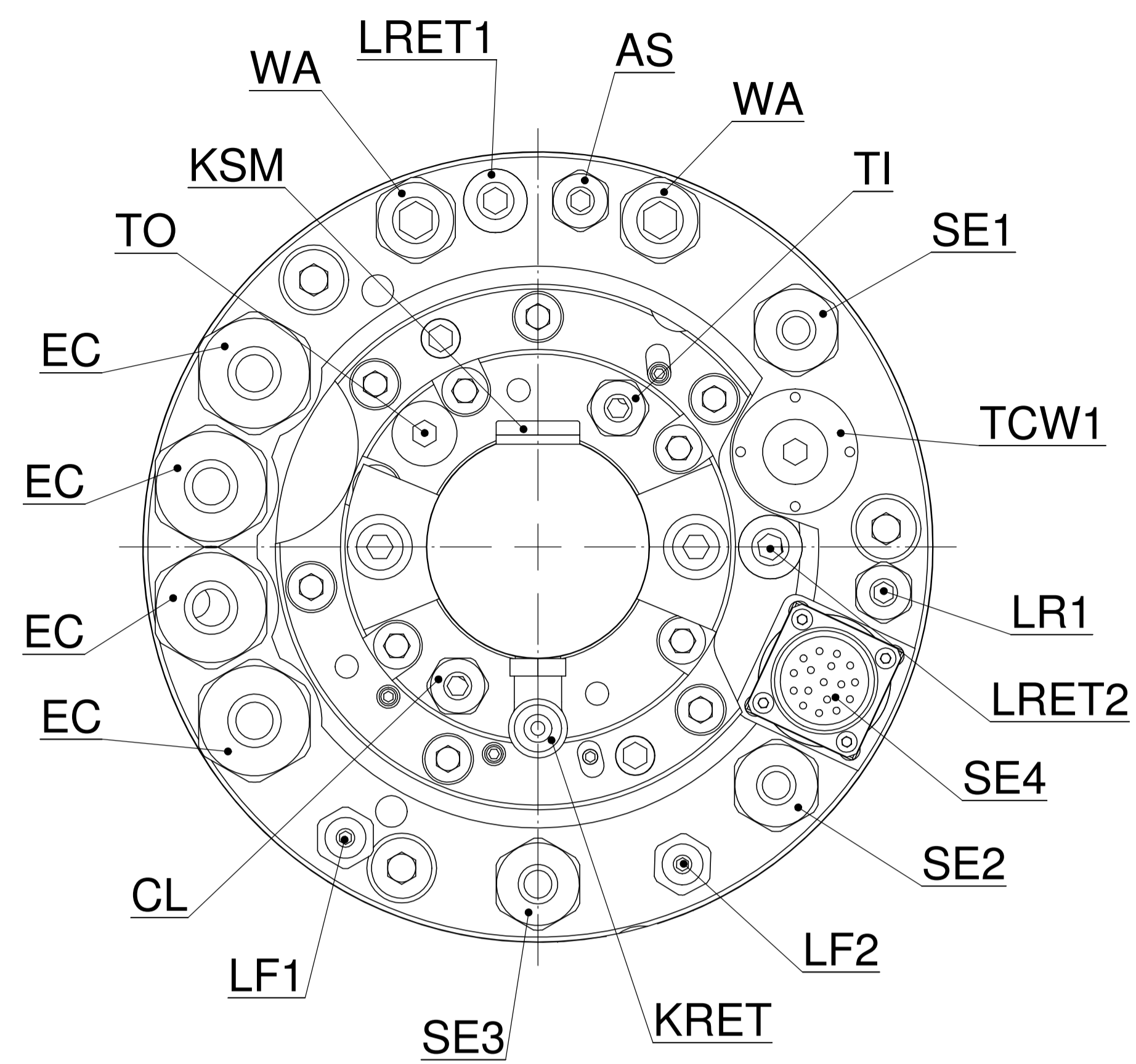

ACHTUNG: Diese Zeichnung zeigt eine Vielzahl von möglichen Options-Varianten. Bitte beachten Sie die technischen Datenblätter und Betriebsanleitung, bzw. die Auftragsbestätigung betreffend der Auslegung und Bestückung Ihrer Spindel.  
ATTENTION: This drawing shows the various possibilities of options for this type of spindle. Please check your technical data sheet, the instruction manual or your order confirmation regarding the type and options of spindle you have ordered/received.

 IBAG Switzerland AG www.ibag.ch	Material/Material:	Verwendungsorte To be used for/in:	Erstellt/Prepared: 19.01.2010 fm	Status/Status: freigegeben
	Gewicht/Weight: 50 kg	Oberfläche/Surface: 1973788 mm <sup>2</sup>	Geprüft/Inspected: 15.07.2013 fm	Blatt Nr./Sheet No.: 1
Benennung/Description: <b>Motorspindel</b> <b>Motor Spindle</b> DIN 69893 - HSK-A/E63 HF 170 AI 22 HIKW		Maßstab/Scale: 1:1 Format/Format: A0 Einheit/Unit: mm	Alte Nummer/Old Number: 170AI22HIKW-01 Zeichnungsnummer/Drawing Number: <b>170AI22HIKW-00</b>	Anz. Blätter/No. of Sheets: 1 Revision: -

We reserve all rights in this document and its subject matter. The recipient hereby acknowledges that this document and its subject matter are the property of IBAG Switzerland AG. This document is for your information only. It is not to be used for reproduction or distribution without the written consent of IBAG Switzerland AG.